

**FRONT VIEW**

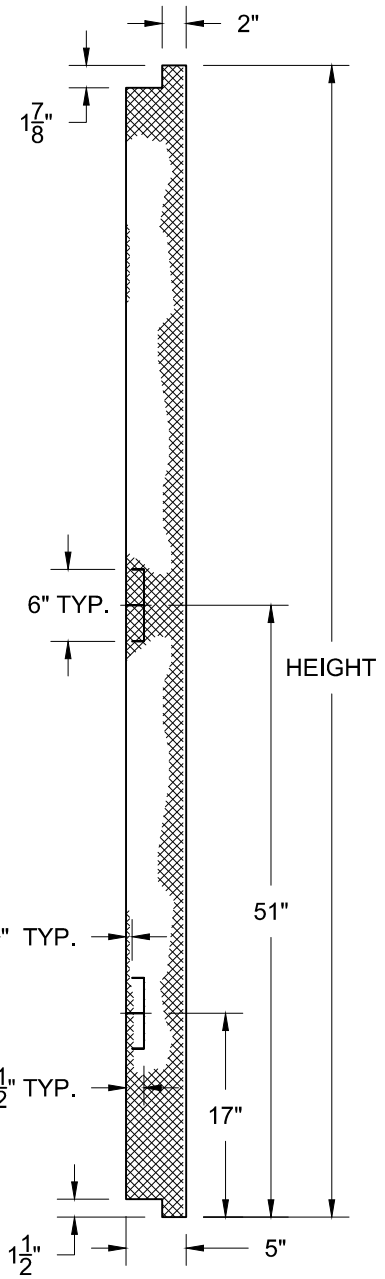

**SECTION A-A**

- NOTE:**
1. STANDARD PANEL HEIGHTS COME IN THREE DIFFERENT SIZES; 96", 108" & 120".
  2. STANDARD PRE-CUT STUD SIZES: 92 5/8", 104 5/8" & 116 5/8"

	TYPE 1 EXPANDED POLYSTYRENE (1 LB DENSITY) INSULATION PANEL	
	<b>EZ SIPS</b>	
DATE:	MAR-03-14	
SCALE:	3/4"=1'-0"	
REVISION:	-	
DWG NO:	EZ SIPS-2x4 / 2	
NK CAD DESIGN www.NKCADD.COM 519-865-8460		